

220 WATT

DS-A4-220

Module output 4mm² cable with locking connectors

ELECTRICAL CHARACTERISTICS

Maximum Power (Pmax)*	220W
Tolerance of Pmax	+/-3%
Type of cell	Polycrystalline
Cell Configuration	60 in series
Open Circuit Voltage(Voc)	36.5V
Maximum Power Voltage(Vpm)	29.6V
Short Circuit Current(Isc)	8.10A
Maximum Power Current(Ipm)	7.44A
Maximum System (DC) Voltage	DC1000V
Series Fuse Rating	15A
NOCT	48°C
Temperature Coefficient (Pmax)	-0.43%/°C
Temperature Coefficient (Voc)	-0.36%/°C
Temperature Coefficient (Isc)	+0.06%/°C

*Measured at (STC) Standard Test Conditions: 25 °C, 1kw/m², AM1.5

MECHANICAL CHARACTERISTICS

Dimensions	65.4" x 39.1" x 1.8" / 1660x992x45mm
Cable Length	35.4" / 900mm
Output Interconnect Cable**	4mm ² cable with Locking Connector
Weight	19.5kg/43.0lbs
Max Load	50 psf (2400 Pascals)
Operating Temperature (cell)	-40°C – 85°C

QUALIFICATIONS



WARRANTY

Output power upto 90% in 10 years, upto 80% in 20 years

IV CURVES

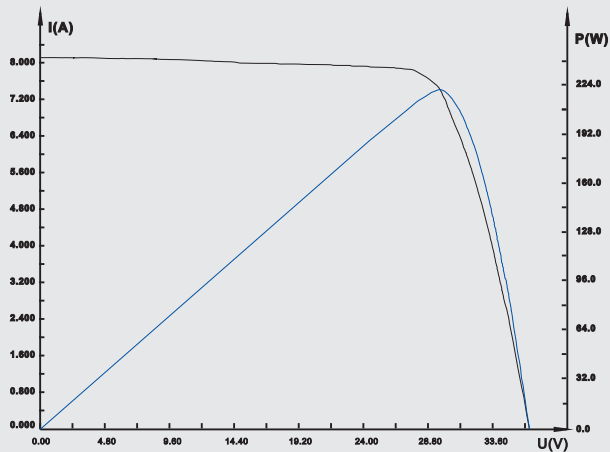

Current, Power vs. Voltage Characteristics

— Current vs. Voltage
— Power vs. Voltage

DIMENSIONS

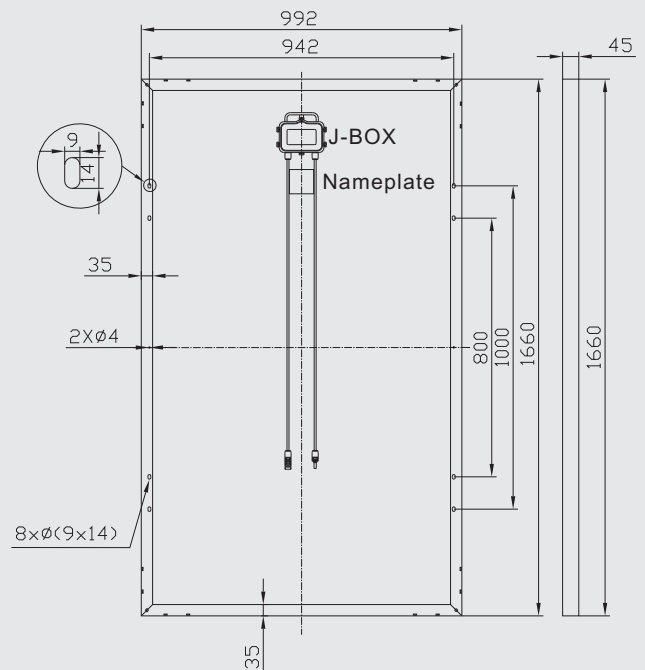

DASOL

Anji DASOL Solar Energy S&T Co., Ltd.
The Health Industrial Park, Anji, Zhejiang 313300, China
www.dasol.cn